

The C1XS X-Ray Spectrometer On Chandrayaan-1

Manuel Grande (1), Brian J. Maddison (2), P. Sreekumar (3), Johani Huovelin (4), Barry J. Kellett (2), Chris J. Howe (2), Ian. A. Crawford (5), D R Smith (6), and the C1XS Team (7),

(1)¹Institute of Mathematical and Physical Sciences, University of Wales, Aberystwyth, SY23 3BZ, UK, (2)Rutherford Appleton Laboratory, Chilton, UK, (3)Space Astronomy & Instrumentation Division, ISRO Satellite Centre, Bangalore, India, (4)The Observatory, Univ. of Helsinki, Finland, (5)School of Earth Sciences, Birkbeck College London, London, UK, (6) Brunel University, Uxbridge, UK, (7) The other members of the C1XS Team are identified in the acknowledgments
M.Grande@aber.ac.uk, Fax: (44)1970 622826

Introduction: The Chandrayaan-1 X-ray Spectrometer (C1XS) is a compact X-ray spectrometer for the Indian Space Research Organisation (ISRO) Chandrayaan-1 lunar mission. It exploits heritage from the D-CIXS instrument (Grande et al 2007[1], 2003 [2]) on ESA's SMART1 mission. However, by comparison with SMART-1, Chandrayaan-1 is intended as a science rather than a technology mission, leading to far more favourable conditions for science measurements. C1XS is designed to measure absolute and relative abundances of major rock-forming elements (principally Mg, Al, Si, Ti, Ca and Fe) in the lunar crust with spatial resolution ~25 km. C1XS is currently integrated on the Chandrayaan-1 spacecraft, awaiting launch in expected in late summer 2008.

The CIXS instrument hardware is built by an international team led from the Rutherford Appleton Laboratory. The Principal Investigator is Prof M. Grande at the University of Wales, Aberystwyth, and there is also a major science and design contribution from ISAC, ISRO, Bangalore, India; CESR, Toulouse, France provide 3-D Plus amplifier assemblies, and there is an important contribution to the detector development from Brunel University, UK. The Science team is chaired by I. A. Crawford. In order to record the incident solar X-ray flux at the Moon, C1XS carries an X-ray Solar Monitor (XSM) provided by the University of Helsinki, Finland.

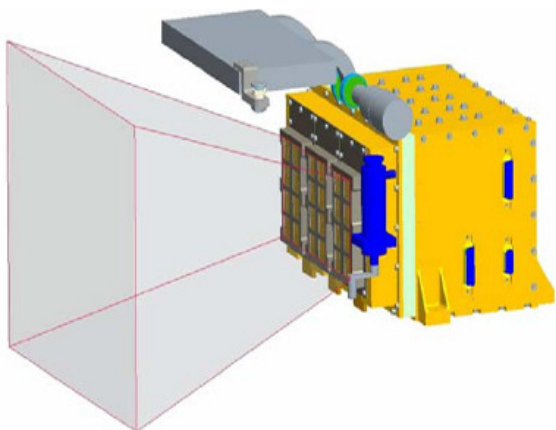

Figure 1: CAD image of the C1XS instrument showing coaligned front detectors, deployable radiation shield and 14° Field of View. Note white thermal gasket separating cool detector enclosure from electronics. (RAL design facility)

Instrument: The baseline design (see fig 1) consists of 24 nadir pointing Swept Charge Device (SCD) detectors, each filtered with 400nm of Al on 400nm of polymer substrate, which provide high detection efficiency in the 1 to 7 keV range, which contains the X-ray fluorescence lines of interest. The SCD is a CCD-like device which achieves near Fano-limited spectroscopy below -10°C. It's read out is similar to a conventional CCD, requiring 575 clock triplets to read out the 1.1cm² detector area. Micro-machined collimators provide a 14 degree FWHM FOV, equivalent to 25 km from 100km altitude. A deployable door protects the instrument during launch and cruise, and also provides a Fe⁵⁵ calibration X-ray sources for each of the detectors.

Careful thought has been given to the radiation shielding, in what is already a comparatively low radiation environment orbit. It will now consist of a 4 mm thick aluminum electronics box with 3mm of copper and 6 mm of tantalum behind the SCD modules. Due to the low altitude, the spacecraft is well shielded from the front by the Moon itself.

Additional refinements to the electronics, onboard software and thermal design will also greatly increase detector stability and signal to noise ratio over what was achieved on D-CIXS [1]. This will result in a significantly improved energy resolution which should therefore be better than 250eV throughout the lifetime of the mission.

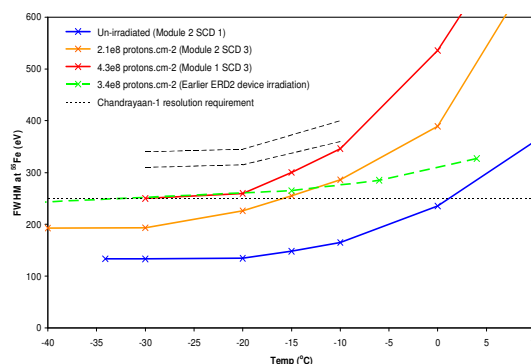

Figure 2: Swept charge device FWHM at Mn-K α vs. temperature, before and after radiation testing. The specified maximum operating temperature is 17.5 ° Note the favourable comparison with D-CIXS performance shown in between the dashed lines. (Brunel Univ.)

In comparison to D-CIXS, C1XS and XSM are far better calibrated (see forthcoming paper by Kellett et al [3]). This applies also to the XSM. One of the lessons learned from D-CIXS was the critical importance of fully characterizing the input Solar spectrum, if one is to derive absolute lunar elemental surface abundances.

X-ray Solar Monitor: The X-ray solar monitor (XSM) consists of a separate Silicon detector unit on the spacecraft. The non-imaging HPSi PIN sensor has a wide field-of-view (FOV) to enable Sun visibility during a significant fraction of the mission lifetime, which is essential for obtaining calibration spectra for the X-ray fluorescence measurements by the imaging C1XS spectrometer. The energy range (1–20 keV), spectral resolution (about 250 eV at 6 keV), and sensitivity (about 7000 cps at flux level of 10^{-4} W m^{-2} in the range 1–8 Å) are tuned to provide optimal knowledge about the Solar X-ray flux on the Lunar surface, matching well with the activating energy range for the fluorescence measured by C1XS.

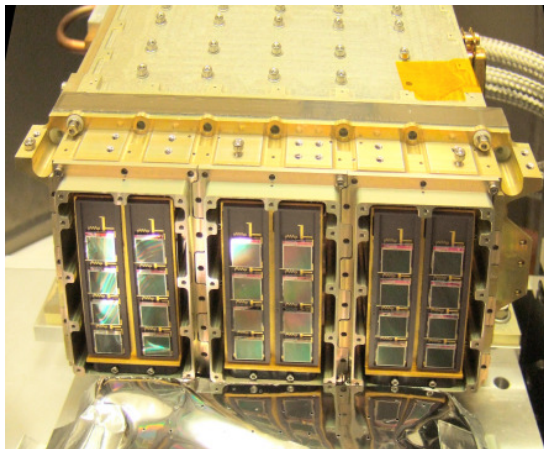

Figure 3: View of the C1XS flight instrument during integration. The collimator assembly and doors have not been added, so that the 24 swept charge detectors, arranged in ladders of four, are clearly seen. (RAL/Aberystwyth)

Science Goals: C1XS will arrive at the Moon in the run up to the maximum of the solar cycle, and the high incident X-ray flux observed from an orbit optimized for science, and coupled with good instrumental energy resolution, means that we will obtain composition data accurate to better than 10% of major elemental abundances over the entire surface. Hence C1XS will be well-placed to make significant contributions to lunar science. Specifically, C1XS will advance our understanding of lunar origins and geological evolution.

It will measure the major element geochemistry (and especially Mg/Si and/or Mg/Fe) in the main lunar terrain types (i.e. Procellarum KREEP Terrain, South Pole-Aitken Basin, and the Farside Highlands) and establish the geographical distribution of magnesian suite rocks. A key ambition is to determine the large-

scale stratigraphy of lower crust (and possibly crust/mantle boundary region) by measuring the elemental abundances of the floor material of large basins not obscured by mare basalts (e.g. SPA and other farside basins), and the central rings and ejecta of large basins (whether flooded or not) which expose material derived from depths of many tens of km.

Aluminium abundance and distribution are critical factors for assessment of lunar refractory element enrichment. Aluminium abundance maps will constrain models of the global melting event that produced the Al-rich crust

In addition, the ~25 km spatial resolution enables C1XS to address a number of smaller-scale geological issues which also refine our understanding of lunar geological evolution. In addition we will obtain major element abundances for regions where samples have been obtained (Apollo, Luna) to validate the calibration of C1XS measurements.

A detailed description of the science objectives for the instrument and the match of its capabilities to key questions is given by Crawford et al [4], and a more detailed discussion of the C1XS instrument and mission can be found in Grande et al 2008 [5]

Acknowledgements

The C1XS Team: M Grande, A Cook, M. Wilding, (University of Wales, Aberystwyth, UK), BJ Maddison, BJ Kellett, CJ Howe (Rutherford Appleton Lab, UK), P. Sreekumar, A Shrivastava, S Narendranath, (ISRO, India), J Huovelin (Helsinki Univ, Finland), I Crawford, K Joy (Birkbeck College London, UK), C L Duston , O Gasnaut, S Maurice, (OMP, Toulouse, France), A Holland, D Smith (Brunel Univ, UK), D Rothery, M Anand (Open University UK), S Russell, Natural History Museum, UK), JN Goswami, N.Bhandari (PRL India), D Lawrence, (Los Alamos National Lab, USA), V Fernandes, (U Coimbra, Portugal), T. Okada, (ISAS, Japan) , O Witasse (ESTEC), C Pieters (Brown University), M Wiczorek (IPG Paris, France).

References:

- [1] Grande M., et al. The D-CIXS X-ray spectrometer on the SMART-1 mission to the Moon—First Results. *Planetary and Space Science*.(2007).
- [2] Grande M., et al, The D-CIXS X-ray mapping spectrometer on SMART-1, *Planetary and Space Science*, 2003, 51, 427-433,
- [3] B Kellett et al 2008, submitted PSS 2008,
- [4] I. Crawford, et al. Submitted PSS 2008.
- [5] M. Grande, et al. Submitted PSS 2008.